

SWITCH MODE POWER SUPPLY



PS18-12

12 Volt 18 Amp

FEATURES:

- Mains Fail Relay Output and Indicator.
- 18 Amp current limited output.
- Fuse blow indication and relay output.
- Temperature switched Fan



DESCRIPTION:

This Boxed supply has 16 independent fused outlets, each one has an intelligent fuse blow detection, lighting up what fuse has blown and triggering a relay output that can be monitored. The 18 amp 12 volt switch mode module inside will provide you very smooth regulation, with plenty of power.

SPECIFICATIONS:

Inputs

Voltage- 230 VAC, +/- 10%
 Frequency- 50 Hz
 Current- 1120 mA
 Protection- 5x20mm, 1.6A Fuse.

Outputs

Total Power- 216 Watts
 Voltage- 12 VDC
 Main O/P Current- 18 Amp
 Hold up time- 20 ms
 Ripple- 150 mV P/P
 Line Regulation- <0.5%
 Load Regulation- <4.1%
 Protection:
 Current- Over load Protection @105-135%
 Voltage- 14.4-16.8V
 Over Temp- >70°C

Efficiency 86%

Isolation

In/Out- 500 V DC / 100M Ohms
 In/Gnd- 500 V DC / 100M Ohms

Temperature

Operating- 0°C to 50°C
 Rise Heatsink- 50°C

Mechanical

Mounting- 4 x 3mm Holes
 Weight- 3.4Kg
 Dimensions- 430 x 190 x 85 mm

Connections

Input- IEC Socket
 Outputs- 2.5mm Removable Rising Clamp.
 (each output has it's own Positive and Negative connection).

Indicators

AC Fail- Green LED
 Fuse Fail- Green LED

Accessories Supplied

-1.5 Meter IEC mains lead

Upgrades Available

-FUSE BD KIT

PS18-12

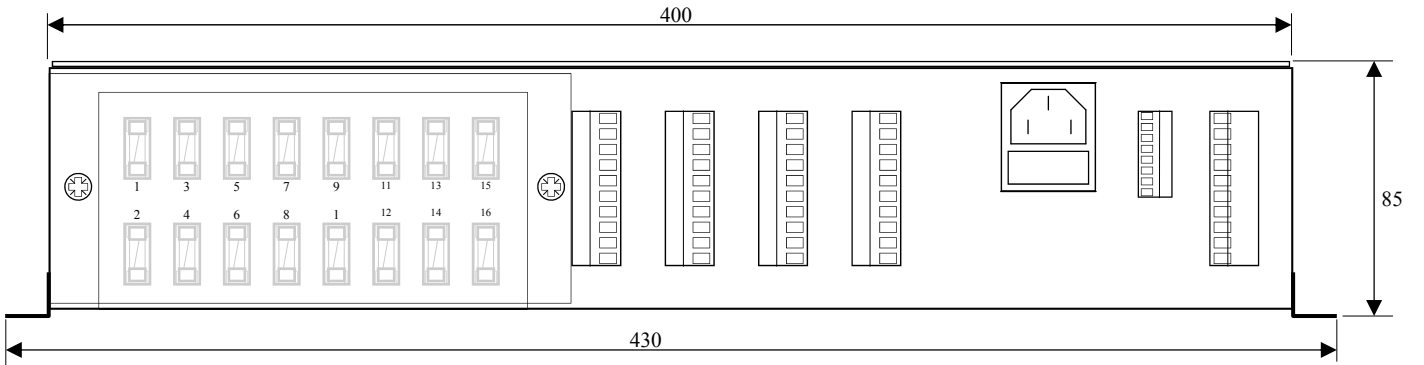
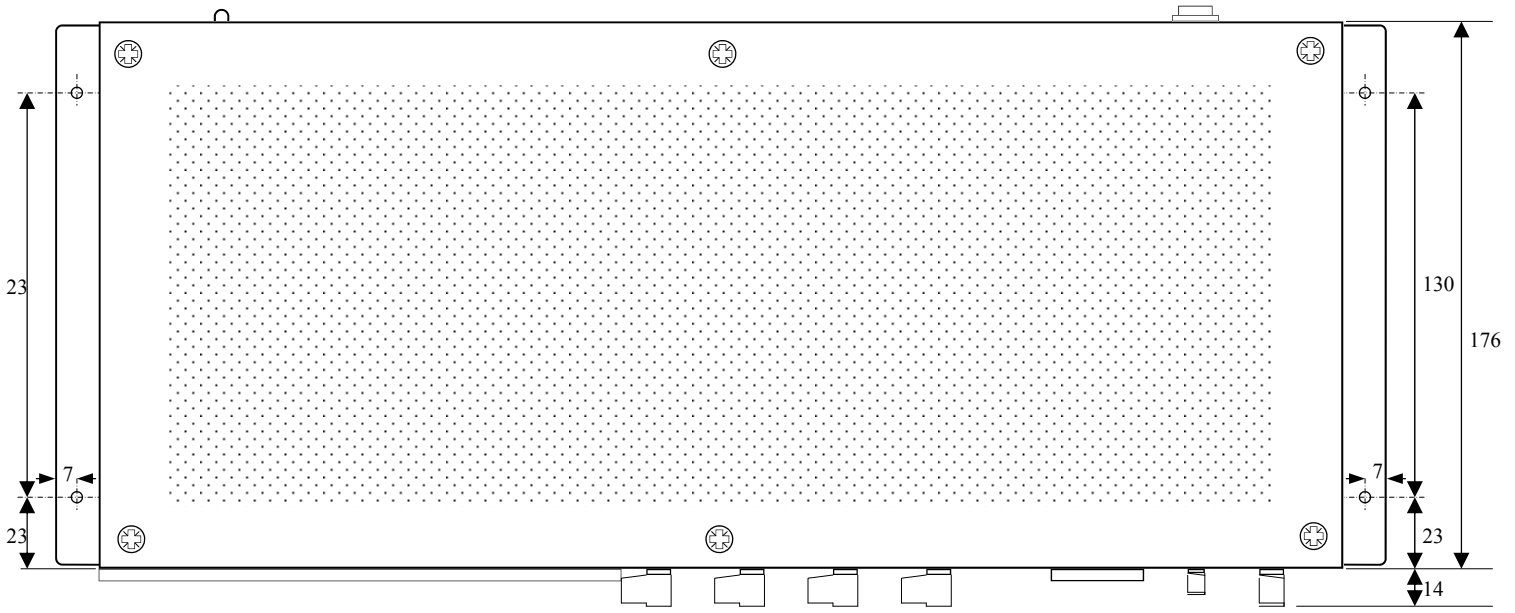

INTRODUCTION:

The PS18-12 is designed as part of a professional security camera installation. It can power up to 16 cameras each via a separate protected output, alarm's are provided to signal supply or fuse fail. The supply comes as a wall mount module, but with the addition of the PS-RK FRONT the supply transforms into an industry standard 2U 19" Rack Case. All connection are via plug in connectors, including the mains for very fast easy installation.

Model Identification

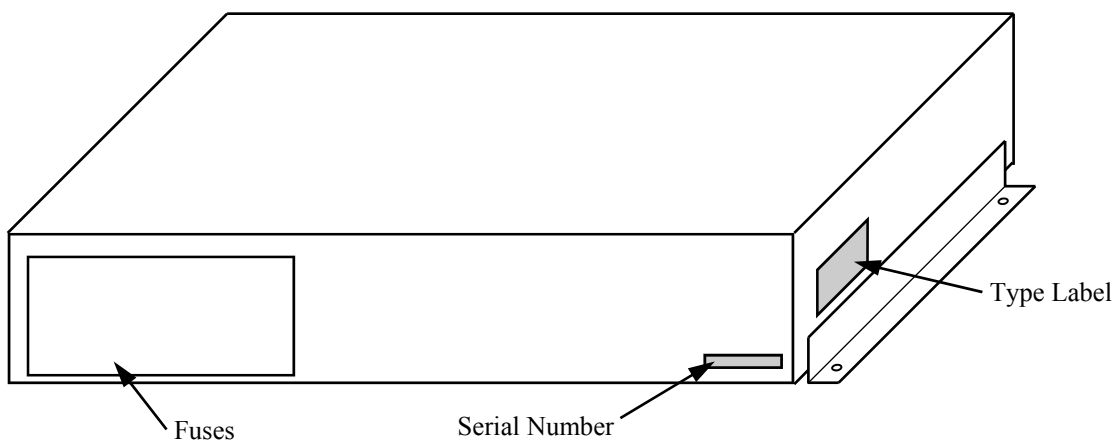

FRONT VIEW OF PS18-12 with PS-RK FRONT (OPTIONAL)

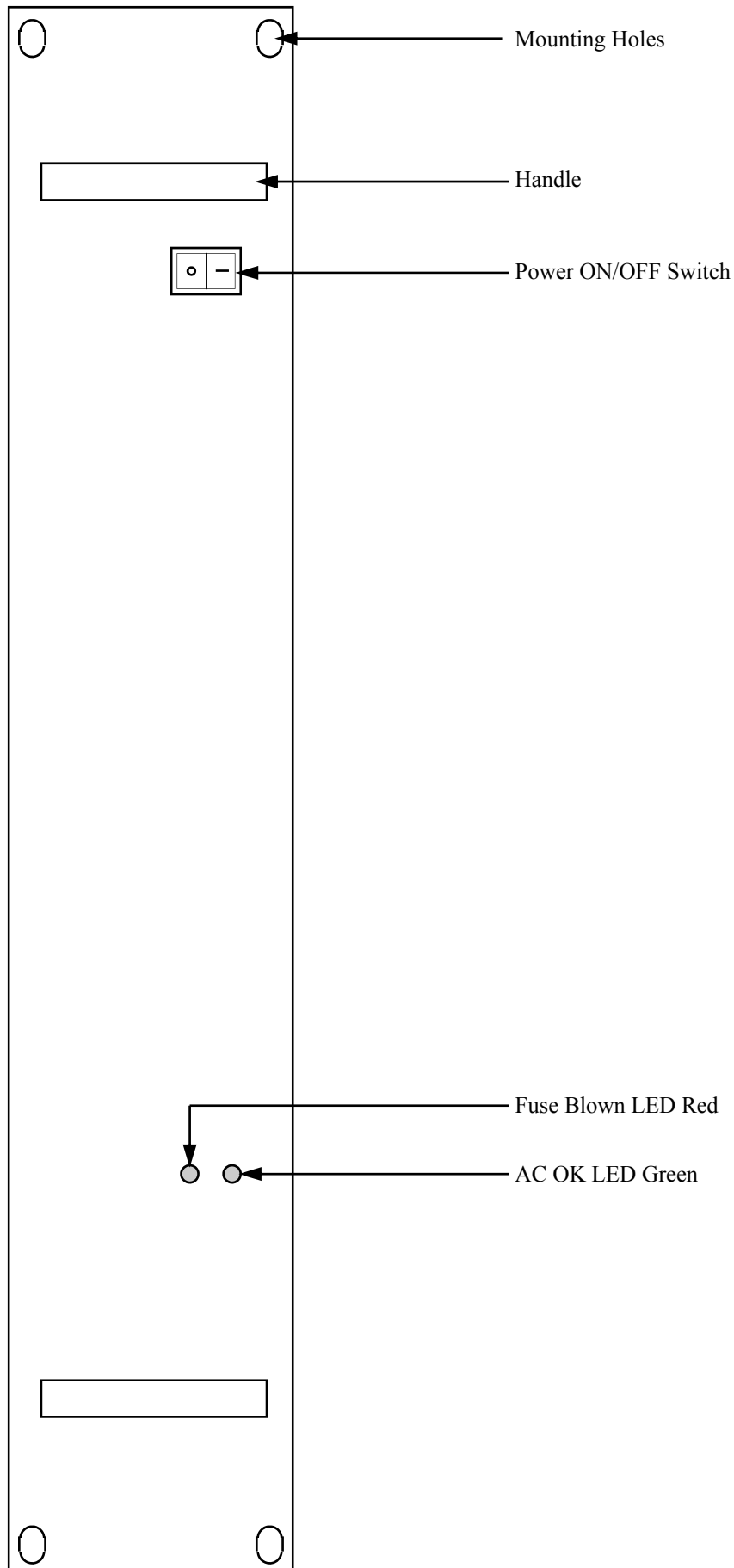

REAR VIEW OF PS18-12

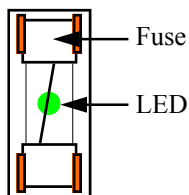
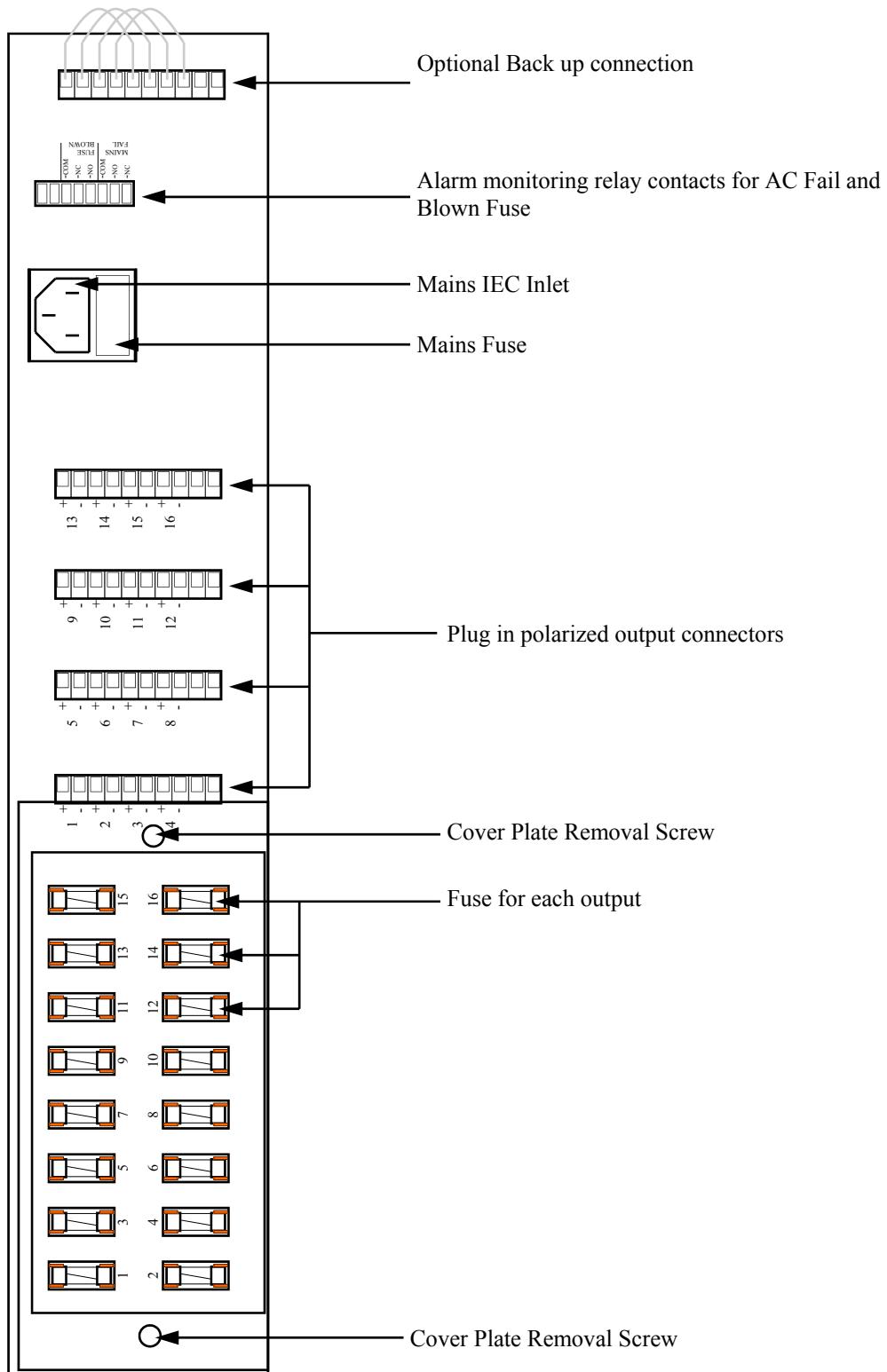

The Green LED in the center of each Fuse holder will illuminate if the fuse is blown. Locate the cause of the Trouble (excessive load, cable short, shorted camera) then follow the instructions under: "Blown Fuse Replacement".

Rack Installation (requires extra kit)

- 1 Install the power supply into the Rack, the best location is at top of the Rack as heat will rise through the top vent cover. If the supply is located at the bottom of a Rack allow at least a 1U space above it for air flow.
- 2 Secure the Rack using the 4 x M6 x 20mm No.2 Pozi screws Provided.
- 3 Determine from the Camera manufactures Data sheet how much current each camera will draw, check that this amount does not exceed 8 Amps or use the Table below.
- 4 Remove the output plug from the back of the supply, connect the first cameras supply cable to the terminals marked ≈1. Repeat for the rest of the cameras, plug the blocks back in. Note only one camera should be connected to each output. As the output is ac, the wires can go either way round 4 cameras connect to each plug in block, the last 2 terminals are unused.
- 5 Plug in the mains IEC power cord.
- 6 Switch on the front panel power switch, the green AC OK LED should be on. The red Fuse Fail LED should not be on, if it is there is a blown output fuse, most likely because of a short on one camera supply cable. Look at the 16 fuses on the rear of the rack to see which one is blown (as indicated by it's green LED being on, See fuse changing).

Warning

- *Do Not block or cover the top ventilation holes, or allow to become Blocked with dust.
- *Do Not Remove the top cover, there are no user or installer serviceable parts inside (fuses are on the rear panel behind the clear cover and in the IEC power connector).
- *Do Not subject the unit to any moisture or spray, cleaning should be done by vacuuming the vent cover or wiping with a soft Dry cloth.
- *Do Not use if any part of this power supply is Damaged, Return it to the manufacture.
- *Do Not use this supply for other than what is intended.

High Power Outputs

If a device with more than 1.6 Amps is required to be run from this supply multiple outputs may be linked together. See Diagram below –note the maximum load is 18 Amp.

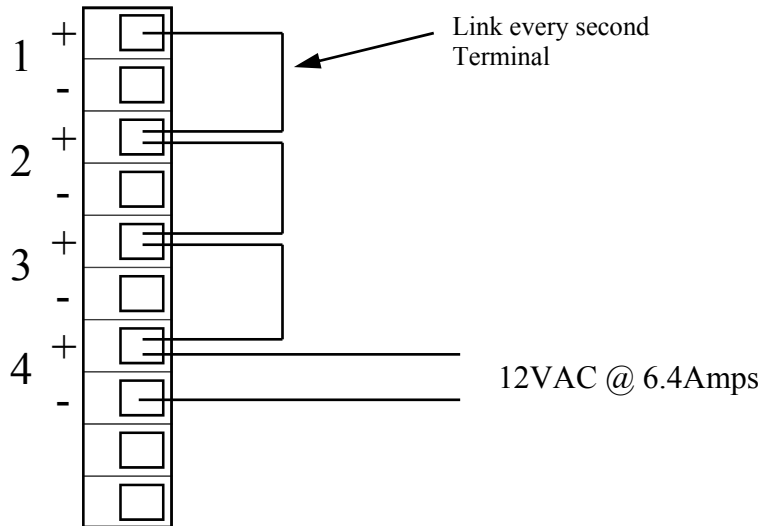

Blown Fuse Indicator

The PS18-12 has 16 Fused outputs, the fuses on the rear are located under a clear protective cover. When a fuse is blown a green LED located in the center of it's fuse holder will illuminate, indicating it is blown.

On the front panel the Red 'Blown Fuse' indicator will also illuminate.

The Blown Fuse relay (form C relay 30VDC @ 1A) will change over, this can be used to signal a monitoring station.

Blown Fuse Replacement - 16 Output Fuses.

Note which fuse is blown by the green LED being illuminated. To replace a blown fuse switch the power supply off at the front panel switch. Remove the two center screws holding the clear protective cover in place. Replace the fuse with one of the same type and rating (1.6A 250VAC). Refit the clear cover.

Blown Fuse Replacement - Mains Fuse

Switch off the supply on the front panel and wall supply, remove the IEC inlet connector from the rear of the power supply, remove the fuse carrier below the IEC connector Replace the fuse with the same type (3A 250VAC 5 x 20mm slow blow).

Arrowhead Alarm Products Ltd.

Phone 09 414 0085
Fax 09 414 0088
Freephone 0800 700 123

WWW.AAP.CO.NZ

344b Rosedale Rd
Albany,
Auckland,
New Zealand.

